



v2.0

0141 772 5537

Jim Smellie,  
15 Tay Crescent,  
Bishopbriggs,  
Glasgow, G64 1EU.

**Kit Reference CC18  
Caledonian Railway D116  
30' Fish Van**

**Prototype Notes and Building Instructions.**

**Section A. Prototype and Livery Notes**

These were built to goods diagram 116 but at some later date appear to have been transferred (without renumbering) to the passenger lists as diagram 85A having been built to the full passenger rated standard sporting an identical underframe to the contemporary CCTs of D87A with both Westinghouse (8" cylinder) and Vaccum (18" cylinder) brake gear.

The stated capacity of the vans was 1620.65 cubic feet and of the ice tanks 117.86 cubic feet. Ice tanks were fitted in each corner and between the doors on both sides. The floor was covered with a  $\frac{3}{4}$ " thick layer of asphalt and the interior of the sides lined with zinc. Iracier axleboxes were fitted when new but it is believed that these would be replaced by the standard oil axleboxes as time wore on. 3'6" diameter wheels were standard.

No trace of them appears in the 1933 L.M.S. passenger rated list so it is presumed that the L.M.S. treated them as goods stock.

It is interesting to speculate what became of these vans. Originally the tanks were filled with ice which melted during the course of the journey but the development of "dry ice" (solid carbon dioxide) during the 1930s rendered this method obsolete, many L.M.S. standard refrigerated vans had their tanks removed and were converted to other uses (e.g. banana vans) around this time. Were any such conversions carried out on these vans ?

L.M.S. numbers and withdrawal dates are currently unknown however the L.M.S. number was normally derived from the C.R. one by adding 300000 (but note that this didn't hold true for the contemporary D101 CCTs). Photographs of the vans are rare making the determination of livery problematic. The liveries shown on the accompanying drawings and described in the following notes are "best guesses" based on standard practice.

## C.R. Livery

Non-passenger coaching stock, fish and meat vans were painted dark purple lake with yellow lining edge with a fine vermilion line at the outer edge. Lettering was medium chrome yellow with the initials "CR" shaded to the left and below in vermilion. After 1913 ironwork was normally black.

When new the roof was white. This, of course, would quickly weather to a grey/black in service. The underframe was black.

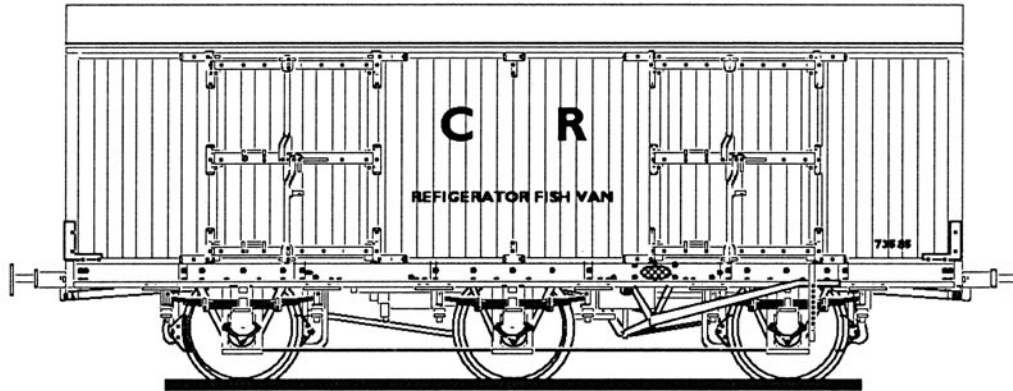

The REFRIGERATOR FISH VAN branding is based on the evidence of a rather indistinct photograph—it might as easily be EMPTY TO ABERDEEN or some such reference to traffic and so shouldn't be taken as gospel.

## LMS Livery

Soon after its inception the LMS adopted the old Midland colour of crimson-lake for its NPCS livery which it is believed was also applied to these vans. Given their style of it is unlikely that they were lined. Roofs were generally painted lead grey but this would soon weather to a muddy grey colour in service.

The insignia was applied in yellow transfers with the company initials in large letters above the centre line between the doors. In some cases the branding FISH would appear below this as shown. The number (3" high) appeared twice at waist height towards each end of the van.

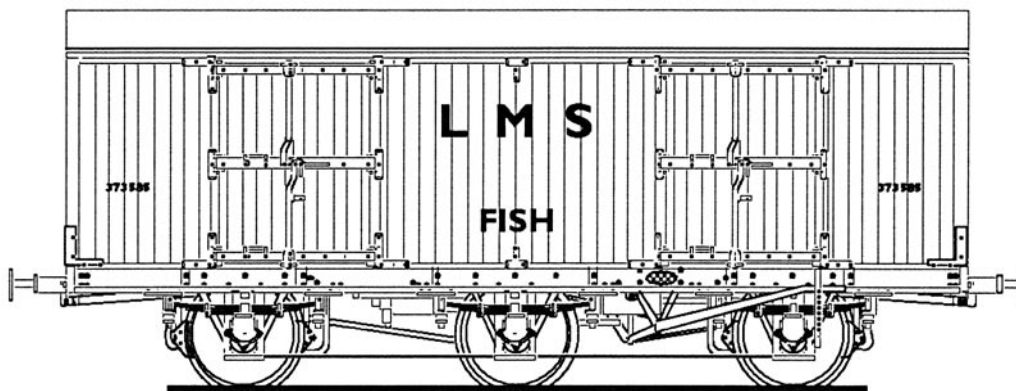

Later (from 1928) the company initials (3" high now) were placed towards the left-hand end and the number towards the right-hand end low down on the body side.

Other changes to the paint specification, if not the actual livery of these vans were :-

1933 Roof colour specified as metallic aluminium.

1936 End colour specified as black.

Wartime Roof colour specified as grey.

## BR Livery

Insulated vehicles were at first white with black lettering but some meat and fish vans were crimson lake or maroon with yellow lettering.

## Livery References :

Britain's Railway Liveries 1825-1948. Carter (Harold Starke, London, 1952)

British Goods Wagons, Essery, Rowland and Steel (David & Charles, Newton Abbot)

LMS Coaches, an illustrated history. Jenkinson & Essery (OPC, Oxford 1977)

## Numbering

Diagram	Lot	C.R. #	LMS #	Built
D85A/116	G351	73585	+ 300000 ?	1914
D85A/116	G351	73586		1914
D85A/116	G351	73587		1914
D85A/116	G351	73588		1914

## Acknowledgements

My thanks are due to the following people have supplied or checked information for these notes :-

The late Duncan Burton, Richard Casserley, Niall Ferguson and Peter Tatlow.

Any error is however my own!

# Caledonian Railway D116 Fish Van

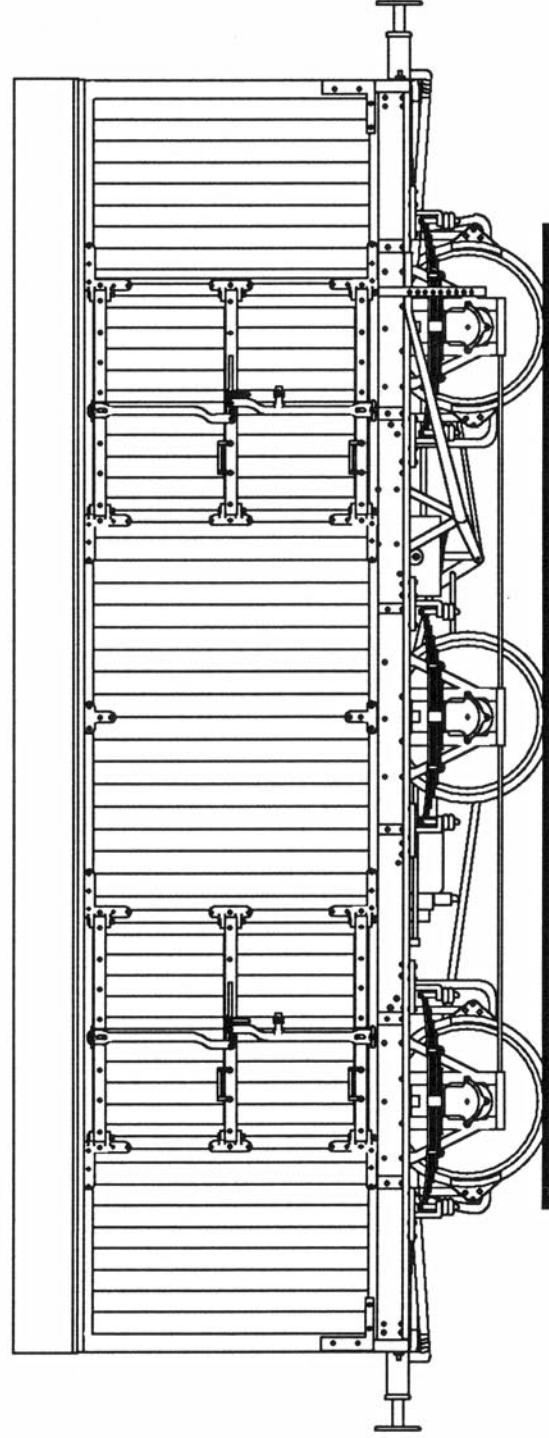

— 10' —

*Jim Smellie Sept '92*

## Section B. Building Instructions

### CC18 Fish Van Parts List

Etched parts comprising :-

- 1\* Main Body
  - 2\* Ends x 2
  - 3\* Solebar
  - 4\* Solebar
  - 7 Roof Formers x 2
  - 7a Central Roof Former
  - 8 Roof
  - 10 "J" hangers x 12
  - 11\* Buffer Beam
  - 12 Door Hinges x 24
  - 13\* Buffer Beam
  - 14\* Door Strapping—middle x 4
  - 15\* Door Strapping—upper & lower x 8
  - 16\* Door Latches x 4
  - 18\* "W" Iron A
  - 19\* "W" Iron B
  - 20\* "W" Iron C
  - 21 Left Hand Brake Hangers and Overlays x 4
  - 22 Right Hand Brake Hangers and Overlays x 4
  - 23 Single Link "V" Hanger x 2
  - 24 Double Link "V" Hanger
  - 25\* Brake Gear Link
  - 26\* Brake Gear "A" Frame
  - 27\* Brake Gear "A" Frame
  - 28 Clutched Brake Lever
  - 29 Clutchless Brake Lever
  - 30 Brake Gear Pull Rod
  - 31 Westinghouse Cylinder Link
  - 32 Brake Lever Ratchets x 2
  - 33 Vacuum Cylinder Link
  - 34 Brake Gear Pull Rod
- Roof Fixing Strap—unnumbered, it is to be found adjacent to part 7A.

Notes :-

- 1 There is a commonality in the part numbering between CC17, CC18 and CC19. Not all part numbers are used by each kit.
- 2 Parts marked with a \* have half-etched rivets which require pressed out.

Lost-wax cast parts comprising :-

- 1 Westinghouse cylinder
- 2 Vacuum cylinder
- 3 Buffer stocks x 4
- 4 Steam pipes x 2
- 5 Westinghouse pipes x 2
- 6 Vacuum pipes x 2

- 7 5' springs x 6
- 8 Iracier axleboxes x 6

(Note : these may be exchanged for oil axleboxes on request—please return them directly to *Caley Coaches* with a note of your name and address)

Miscellaneous parts comprising :-

- 1 8BA nut and bolt
- 2 "Waisted" pin-point wheel bearings x 6
- 3 Buffer heads and shanks x 4
- 4 Buffer bushes x 4
- 5 Buffer springs x 4
- 6 Phosphor Bronze wire
- 7 0.45mm wire

## Part 1 Basic Body Shell

- 1.1) Tin the narrow strips attached to the top of the sides (part 1) and the top of the sides themselves. Fold the strips through 180° such that they lie on top of the outside of the body and sweat together.
- 1.2) Press out the rivet detail on the two ends (parts 2) and on the main body. Solder one side/end join after locating the tab on the end in the cut-out in the side. Take care the parts are square to each other. Solder the other three side/end joins in a similar manner.
- 1.3) Press out the myriad of rivets on the solebars (parts 3 and 4), fold each to an "L" shape and solder in position on the underframe. Note that the parts are handed and will only fit one way round.
- 1.4) Press out the rivet detail on the sides and ends. Fold up the van sides from the floor pan on part 1 and then fold down :-
  - a) Underframe cross-member ends,
  - b) Location tabs for W irons "B" and "C" and
  - c) Buffer beam location plates.

**Do not fold down the wire guides either side of W iron B.**
- 1.5) The buffer beams (parts 11 and 13) are a three layer sandwich. Fold the lamp irons on the central layer to 90° and then tin both sides of this layer. Fold up the sandwich, passing the lamp irons through the slots in the front layer and solder the layers together. File off the linking tams and fold the lamp irons back up parallel to the beam. (Use a piece of scrap fret as a spacer.)

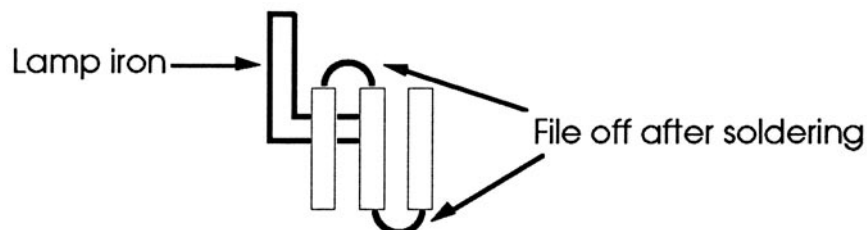

- 1.6) Solder the buffer beams in place on the floor pan lining up the safety chain holes with those on the van ends.

## Part 2 Roof

- 2.1) The roof is fabricated from three formers (parts 7 and 7A), a skin (part 8) and a fixing bracket (unnumbered). Part 7A is the central former and the area on it marked "D" mates with the end of the fixing bracket which is similarly marked.
- 2.2) The curvature of the skin is best formed by placing a piece of tube ( $\frac{1}{2}$ " central heating pipe, broom handle etc.) along the axis of curvature while pressing against a firmish (but not too firm) surface—a pile of newspapers on top of the workbench should do.  
  
Take thing gently and the curve should soon start to form—check regularly against the formers to make sure you don't over do it.
- 2.3) Using a smaller diameter tube, form the tighter curves at the outer edges of the roofs in a similar manner—the half etched lines will assist you in this.
- 2.4) Solder the shaped skin to the formers starting with a tack in the centre of each and gradually working outwards.
- 2.5) Solder an 8BA nut over the hole in the roof fixing strap and fold over the end to form an "L".

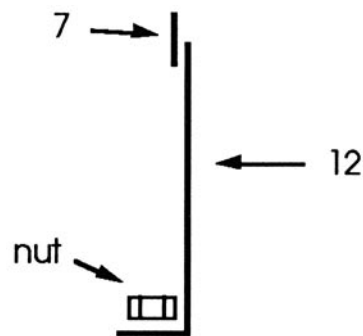

- 2.6) Solder the roof fixing strap to the section of the central roof former marked "D".
- 2.7) Check the fit of the roof on the body and adjust as required. The captive nut should screw up into the nut holding everything firm.
- 2.8) Remove the roof and set it aside while further construction proceeds.

## Part 3 Body Detail

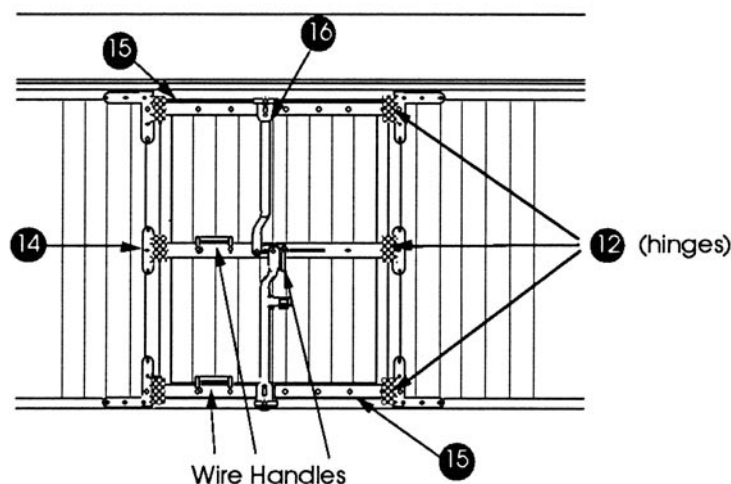

3.1) Fold all 24 hinges (part 12) in half thus :-



3.2) Press out the rivet detail on the door strapping (parts 14 and 15) and tin their rears.

3.3) In turn, pin each piece of strapping in place using two hinges. Solder the hinges in place from inside the body, then flux the strap and apply heat to the outside to make it lie down on the body.

3.4) Solder the door latches (part 16) in place.

3.5) Form a wire handles as indicated in the drawing above and fix in place.

3.6) Drill out the buffer bases to 1mm, fit bushes to the rear and fix in place on the van. Fit the heads and springs either now or after painting as preferred.

Tip—take a small piece of 60 thou. plasticard and cut a notch in it. Place this behind the buffer head to space it out from the buffer body and then fold over the tail of the buffer shank. This ensures a constant standoff for each buffer.

#### **Part 4 Running Gear**

4.1) Press out the rivet detail on the W iron assemblies (parts 18, 19 and 20) and on each fold down the W irons and longitudinal strengthening ribs—reinforce the folds with solder. Bend back the “ears” which carry the tie bars to 90° and fold the axlebox retaining plates to 180°, the latter going outside the main W iron, and solder in place.

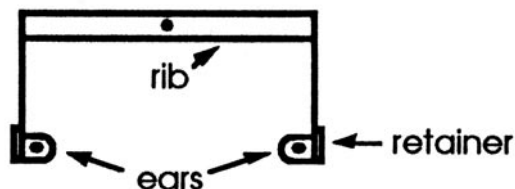

4.2) Solder assembly A (part 18) to the floor pan in the position marked by the corresponding letter.

4.3) Place assembly B on the floor pan between the lugs either side of location B on the floor pan. Retain in place by bending over the tangs of the lugs.



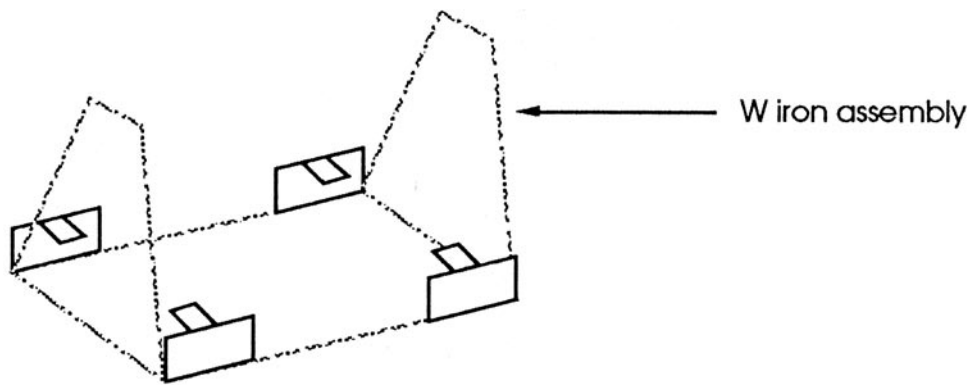

- 4.4) Place assembly C on the rocking edge at location C and retain by bending one of the tabs provided at 180° to the floor of the rocking W iron assembly. (The other tab is provided as a spare to allow later dismantling.)

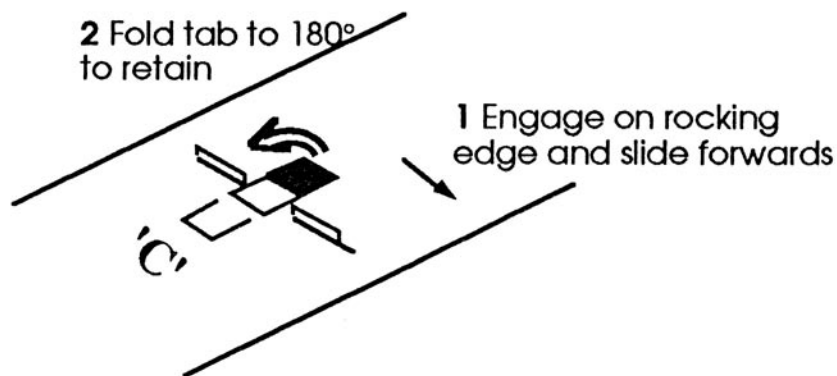

- 4.5) Thread a length of phosphor bronze wire through the holes in the strengthening ribs of all three W iron assemblies. Firmly solder this to the outer ends of assembly A only. Fold down the wire tensioners from the floor pan either side of assembly B until they engage the wire lightly. These are finally adjusted once the van is up and running on its wheels. Crank the wire at W iron assembly B to clear the roof fixing bolt hole.
- 4.6) The brake hangers and blocks are handed—part 21 being left handed, part 22 right handed. On all eight hangers, fold over the block detail overlay and solder in place.

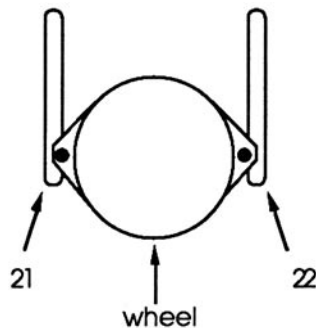

- 4.7) The hangers locate in the slots on W iron assemblies A and C, each having two possible locations. Use the outer set of slots for P4 and EM or the inner ones for OO and solder in place.
- 4.8) **STUDY THE DIAGRAM OF THE BRAKE RIGGING CAREFULLY BEFORE PROCEEDING.**

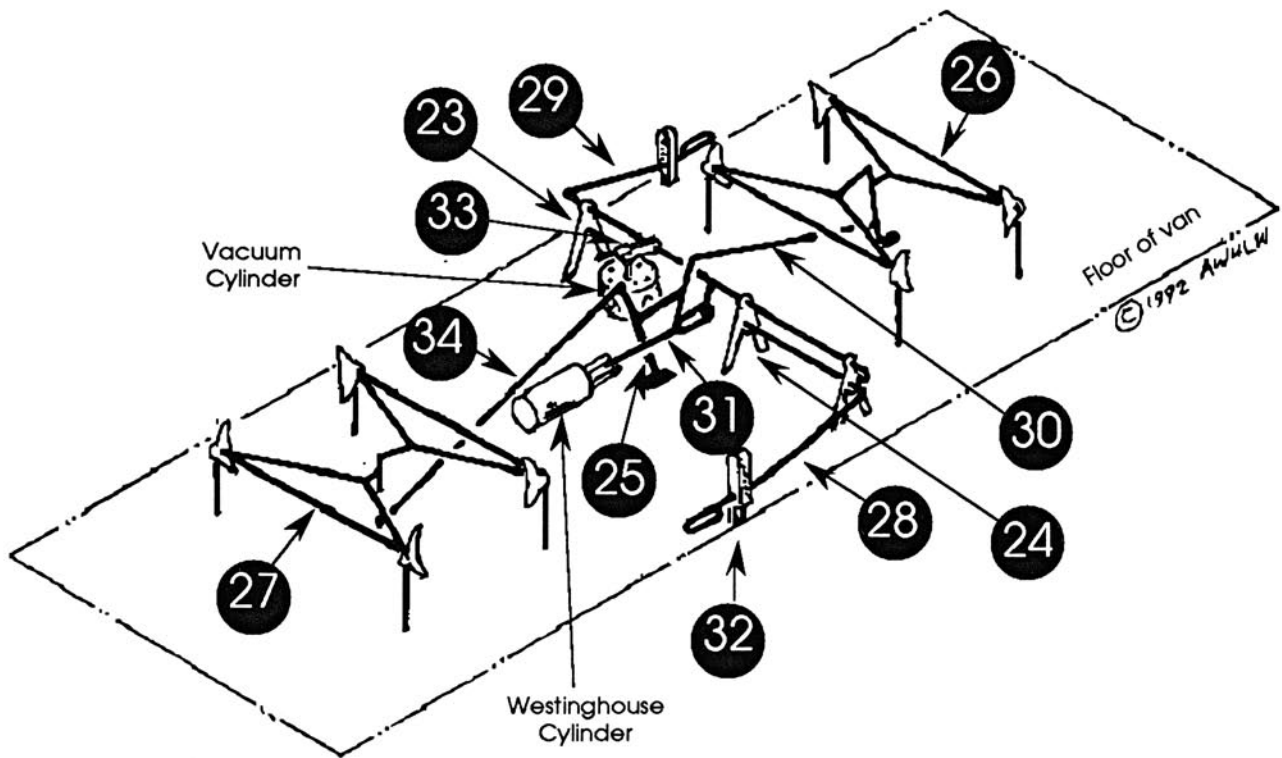

## DIAGRAM OF BRAKE RIGGING

5522-080-0

- 4.9) Solder the Westinghouse and Vacuum brake cylinder castings to the floor pan in the indicated positions. Note that the smaller diameter end of the Westinghouse cylinder goes nearest the centre of the van.
- 4.10) Solder the V hangers to the floor pan. Looking from underneath, one part 24 (with the holes for two link rods) goes nearest you, the other goes near the van centre line and part 23 (with a hole for only one link rod) goes inside the opposite solebar.
- 4.11) Thread a length of 0.45mm wire through the upper holes of part 28 and the fold down V hanger and solder in place. Leave the end of the wire protruding below the solebar for now.
- 4.12) Crank the ends of the vacuum cylinder link (part 33) and fold it in half to produce the shape sketched below.

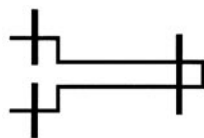

- 4.13) Thread a length of 0.45mm wire through the remaining hole on all three brake hangers, threading the Westinghouse cylinder link (part 31) and the vacuum cylinder link onto the section between the two V hangers attached at §3.10—check the brake rigging diagram for the orientation etc. Leave the wire overlong below both solebars.
- 4.14) Align part 31 with the Westinghouse cylinder and solder in place. Similarly align and fix part 33 to the vacuum cylinder.

- 4.15) Solder a wheel bearing to each W iron and mount the wheels of your choice.
- 4.16) On parts 26 and 27, twist the two A frame sections to 90° relative to their central linking section (see sketches below and the brake rigging diagram) and fix to the brake hangers noting the correct orientation.

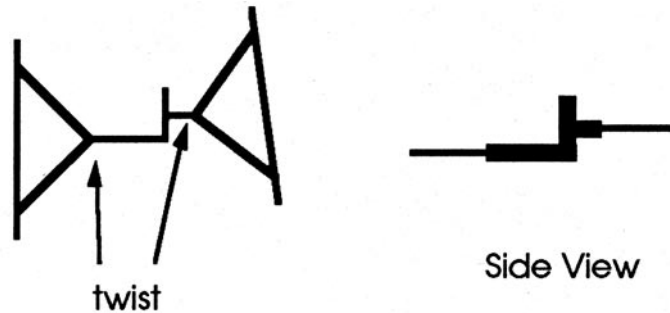

- 4.17) Part 25 has a fold over lug for fixing it to the van floor. Fold this lug to 90° and tin with solder. Align the hole furthest away from this lug with the hole next to the slot on part 31 (see sketch) keeping the lug flat on the underside of the floor and solder in place.

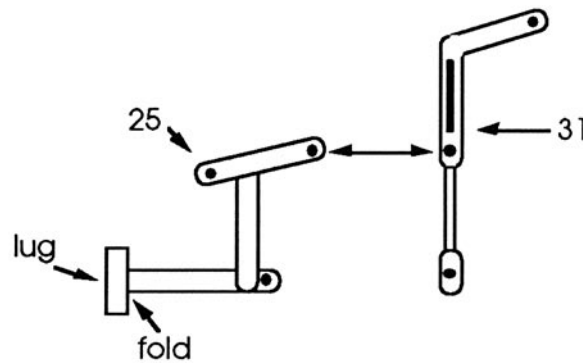

- 4.18) The pull rods (parts 30 and 34) link part 25 with the central sections of the A frames. Align and fix as per the brake rigging diagram.
- 4.19) Fold up the two brake lever ratchets to form a U shape thus :-



(All folds are marked by 1/2 etch lines.) Solder in place on the underframe—the locations being denoted by small slots in the floor outside of the solebar.

- 4.20) Fold up the ends of the hand brake levers (parts 28 and 29) to form handles thus :-



- 4.21) Pass the ends of the brake levers through a ratchet and mate with the wires protruding from the corresponding V hanger—part 28 to the side with 2 wires, part 29 the other. Solder in place and trim back any excess length of wire.

- 4.22) Take two lengths of 0.45mm wire about 71m long. Starting at the outer end of the rocking W iron assembly (C) thread through the lugs on the three W irons to form the tie bars.

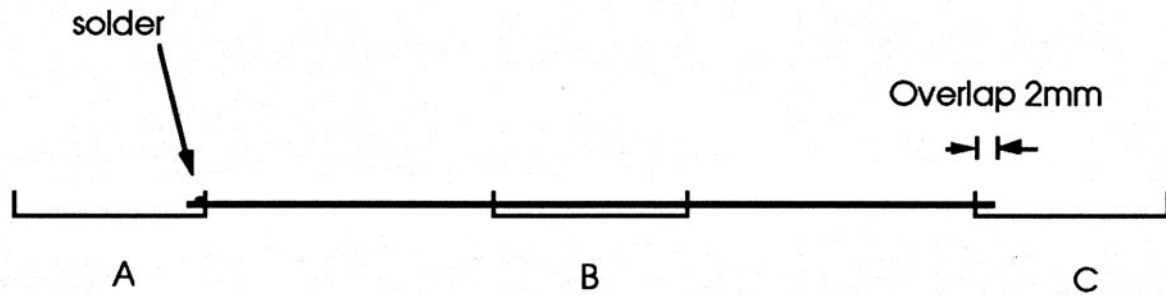

Solder in place at end A only so that the motion of the other two W irons is not impeded.

- 4.23) The chassis is completed cosmetically by fixing (by glue or solder) the axleboxes over the wheel bearings and the springs to the solebars above them.
- 4.24) Paint, line and letter your van according to period.
- 4.25) Fit the roof and buffer heads if you have not already done so.

## Part 5 Suspension Tuning

Adjust the tension in the phosphor bronze wire using the the two adjuster lugs either side of W iron assembly B so that their is slight downward pressure on the central axle when the van is placed on the track.

You are aiming at the minimum amount of pressure required to hold the central axle on the track (so that 3 point suspension is achieved via the outer two axles). A little trial and error while test running the van should give you this.

## Acknowledgements

My thanks are due to Alistair Wright for the artwork and design, Owen Lancaster and Laurence Griffen for patternmaking and Ian Young for the lost-wax casting. I must also thank you for buying the kit!

## Other items in the *Caley Coaches* range

*Caley Coaches* now produces a wide range of kits and accessories in 4mm scale (plus a few 7mm scale items) for devotees of the Caledonian Railway. See [www.caley.com](http://www.caley.com)

## Copyright

All etched and cast parts are the copyright © of *Caley Coaches*

All rights are reserved and any use of any tradenames or trademarks owned by other persons or companies is acknowledged.

*Jim Smellie*